

The information in this document is subject to change without notice and should not be construed as a commitment by ABB. ABB assumes no responsibility for any errors that may appear in this document.

Except as may be expressly stated anywhere in this document, nothing herein shall be construed as any kind of guarantee or warranty by ABB for losses, damages to persons or property, fitness for a specific purpose or the like.

In no event shall ABB be liable for incidental or consequential damages arising from use of this document.

This document and parts thereof must not be reproduced or copied without ABB's written permission, and contents thereof must not be imparted to a third party nor be used for any unauthorized purpose. Contravention will be prosecuted.

Additional copies of this document may be obtained from ABB at its then current charge.

© Copyright 2021 ABB ALL right reserved.

ABB

SE-721 68 Västerås
Sweden

Latest revision: ECO 116452, new.



Lab/Office:
RMRO SE
RDM2

IRB 5710/5720

COPYRIGHT page

Status: 2021-10-29

APPROVED

Document no.

3HAC080367-001

Plant: = IRB57XX
Location: + Manipulator
Sublocation: +

Rev. Ind

00

Page 1

2

Total 13

Prepared by, date: Mattias Lindevall

Approved by, date: Mattias Lövmemark

Table of contents

ABB Contents1

Page	Page description	Comment
1	COPYRIGHT page	
2	Table of contents: (1 - 80)	
3	Valid For	
4	Location of connection points	
5	Legend	
10	Brake Release Unit	
20	Serial Measuring Board	Incl. 7th axis connection (optional)
30	Axis 1	
40	Axis 2	
50	Axis 3	
60	Axis 4	
70	Axis 5	
80	Axis 6	

We reserve all rights in this document and in the information contained therein. Reproduction, use or disclosure to third parties without express authority is strictly forbidden. © Copyright 2003 ABB

Valid For:
 This circuit diagram is valid for the following cable harness assemblies:
 3HAC071396-001: Manipulator harness axis 1-6
 3HAC072848-001: Brake release unit
 3HAC043904-001: SMB unit
 3HAC15619-1: Cable, FB7-SMB 1.7
 3HAC044075-001: Battery unit
 3HAC073539-001: Cable, battery-SMB

We reserve all rights in this document and in the information contained therein. Reproduction, use or disclosure to third parties without express authority is strictly forbidden. © Copyright 2003 ABB

Latest revision: ECO 116452, new.



Lab/Office:
 RMRO SE
 RDM2

IRB 5710/5720

Valid For

Status: 2021-10-29

APPROVED

Document no.

3HAC080367-001

Plant: = IRB57XX
 Location: + Manipulator
 Sublocation: +

Rev. Ind
00

Page 3
 4
 Total 13

Prepared by, date: Mattias Lindevall

Approved by, date: Mattias Lövmemark

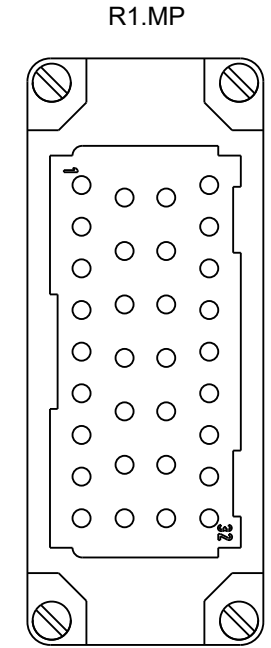
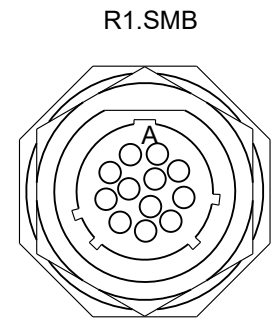
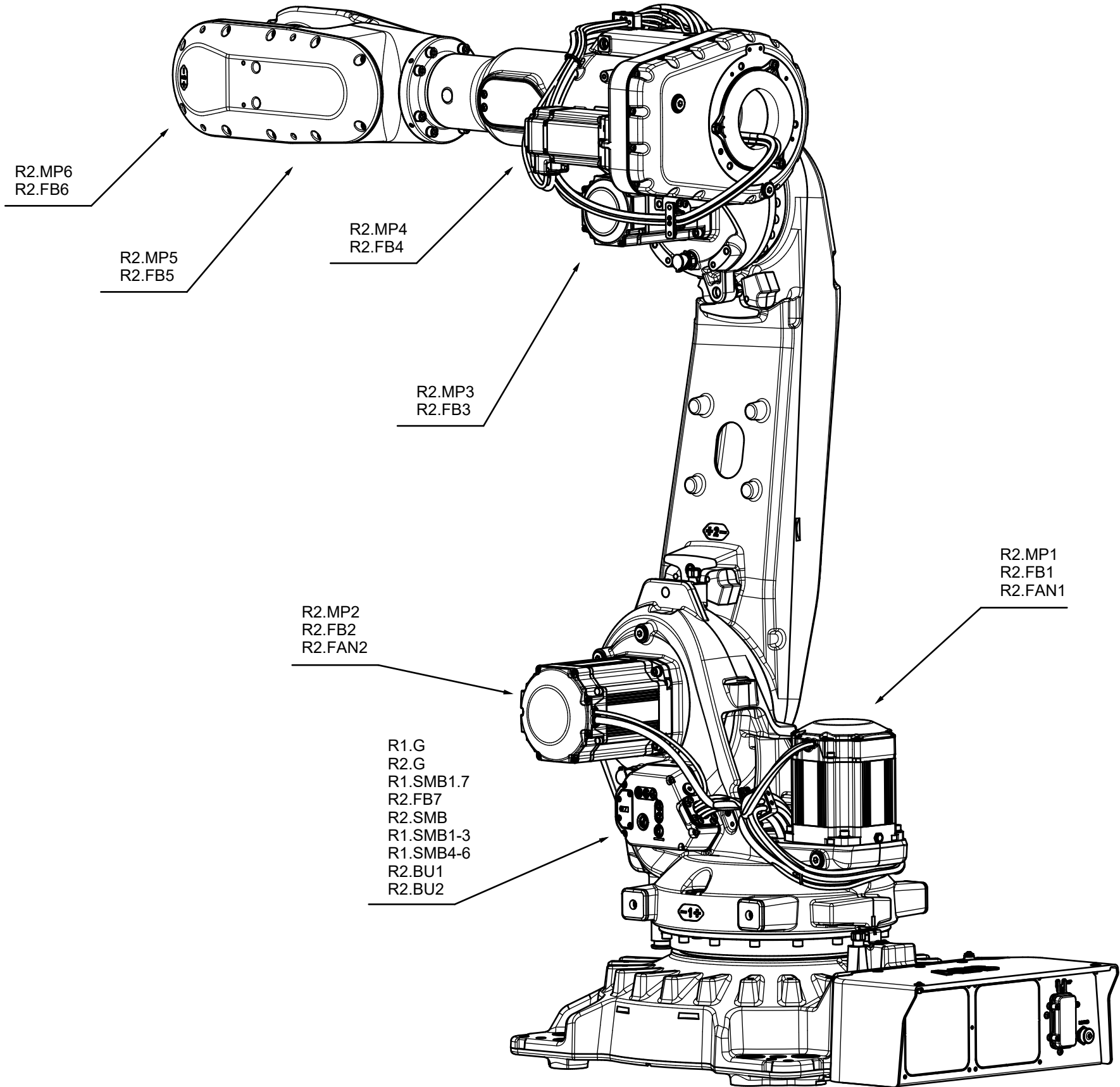

We reserve all rights in this document and in the information contained therein. Reproduction, use or disclosure to third parties without express authority is strictly forbidden. © Copyright 2003 ABB



**IRB 5710
IRB 5720**

Latest revision: ECO 116452, new.		ABB	Lab/Office: RMRO SE RDM2	IRB 5710/5720	Status: 2021-10-29	Plant: = IRB57XX
Prepared by, date: Mattias Lindevall			Approved by, date: Mattias Lövmemark	Location of connection points		APPROVED
					Document no. 3HAC080367-001	Sublocation: +
					Rev. Ind 00	Page 4 5 Total 13

We reserve all rights in this document and in the information contained therein. Reproduction, use or disclosure to third parties without express authority is strictly forbidden. © Copyright 2003 ABB

1	2	3	4	5	6	7	8
M	Motor				Protective Earth		
B	Brake						
PTC	Temp sensor (PTC- resistor)				Twisted wires		
R	Resolver						
G	Battery Pack				Screened wires		
BU	Brake Release Unit				Varistor		
FB	Feedback unit				Resistor		
SMB	Serial Measurment Board						
FAN	Fan				Diode		
SW	Position switch						
Keypin	Location pin to avoid mismatch						

We reserve all rights in this document and in the information contained therein. Reproduction, use or disclosure to third parties without express authority is strictly forbidden. © Copyright 2003 ABB

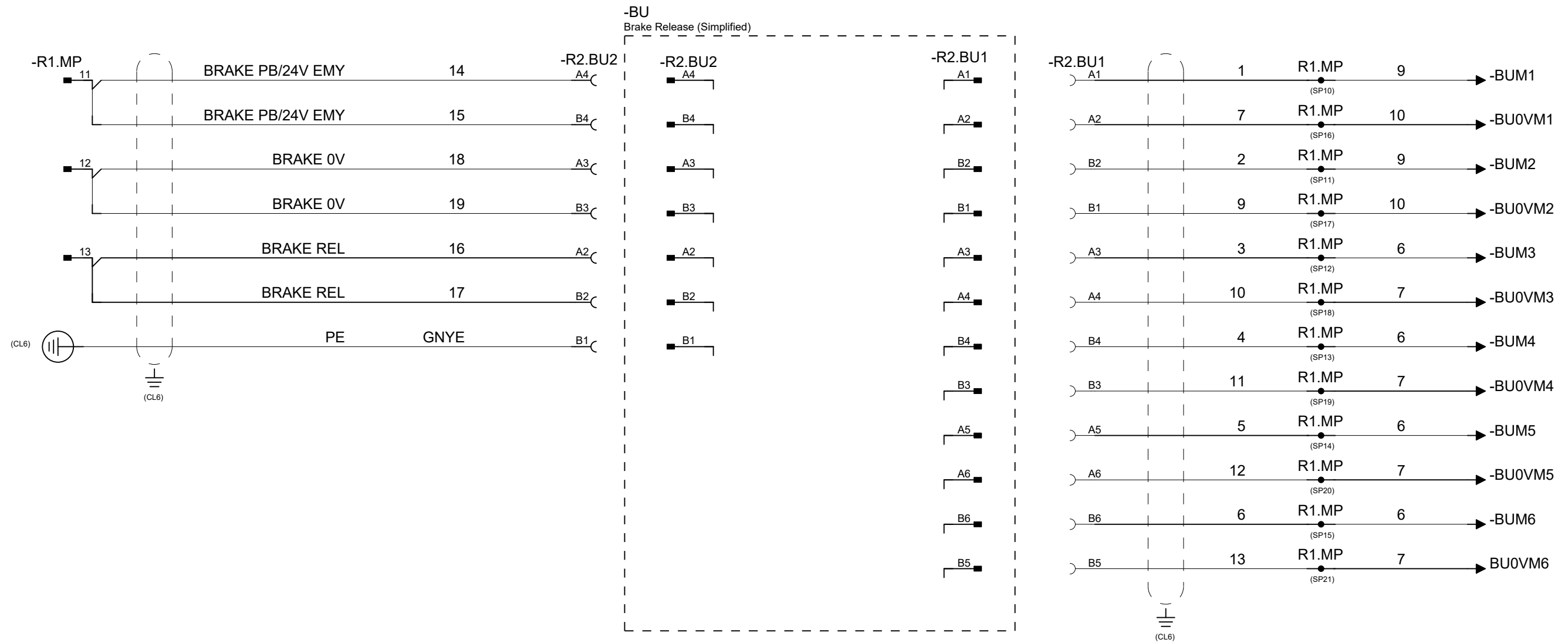

Latest revision: ECO 116452, new.

Prepared by, date: Mattias Lindevall Approved by, date: Mattias Lövmemark

ABB
Lab/Office:
RMRO SE
RDM2

IRB 5710/5720
Brake Release Unit

Status: 2021-10-29
APPROVED
Document no. 3HAC080367-001

Plant: = IRB57XX
Location: + BU
Sublocation: +

Rev. Ind 00 Page 10
+SMB/2D
Total 13

We reserve all rights in this document and in the information contained therein. Reproduction, use or disclosure to third parties without express authority is strictly forbidden. © Copyright 2003 ABB

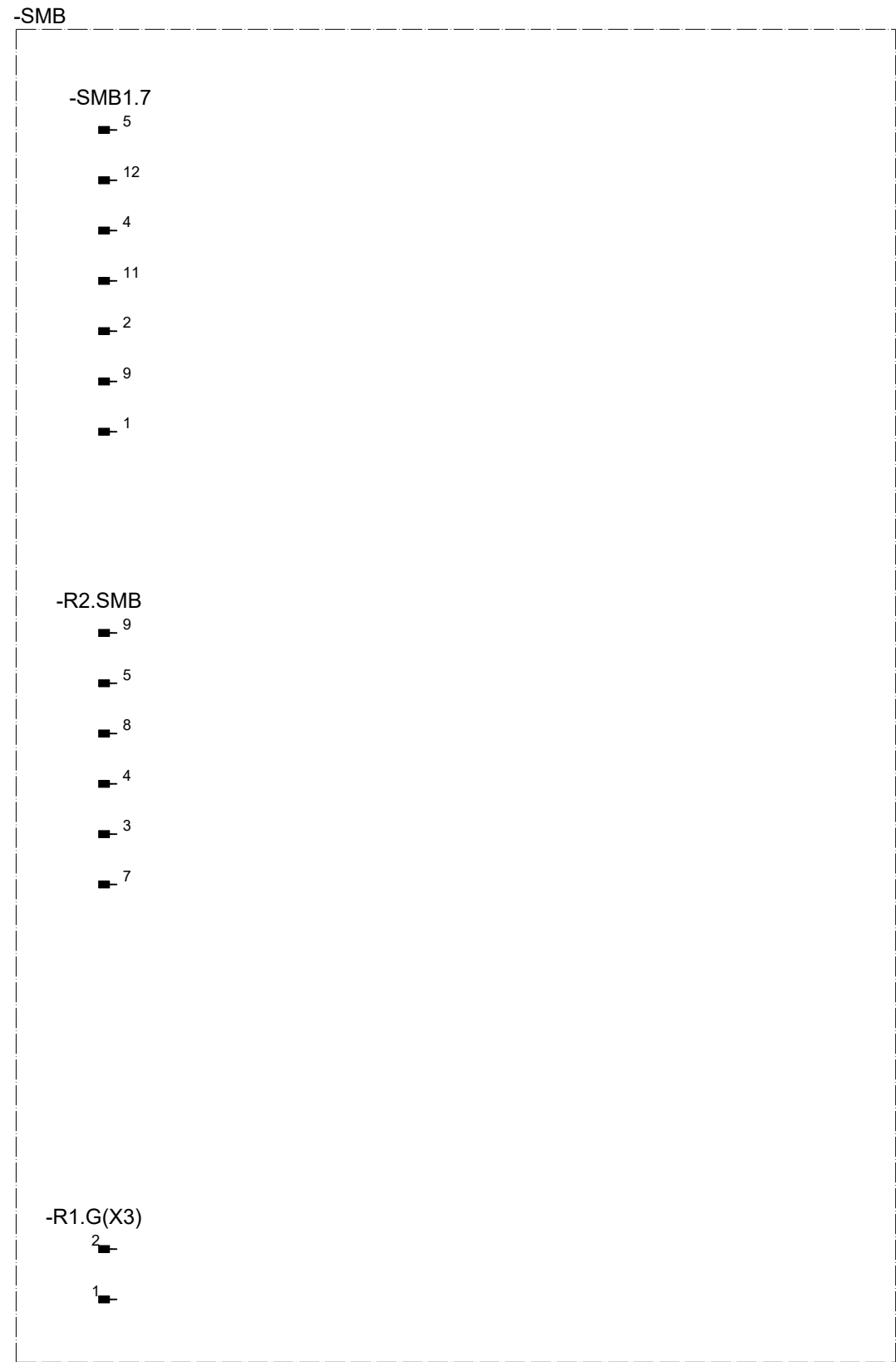
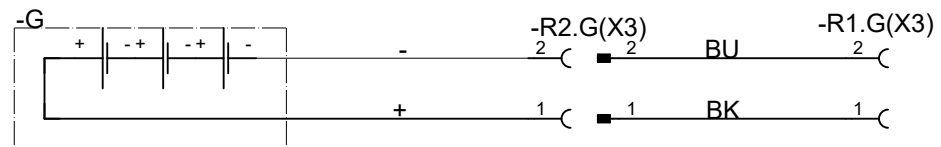
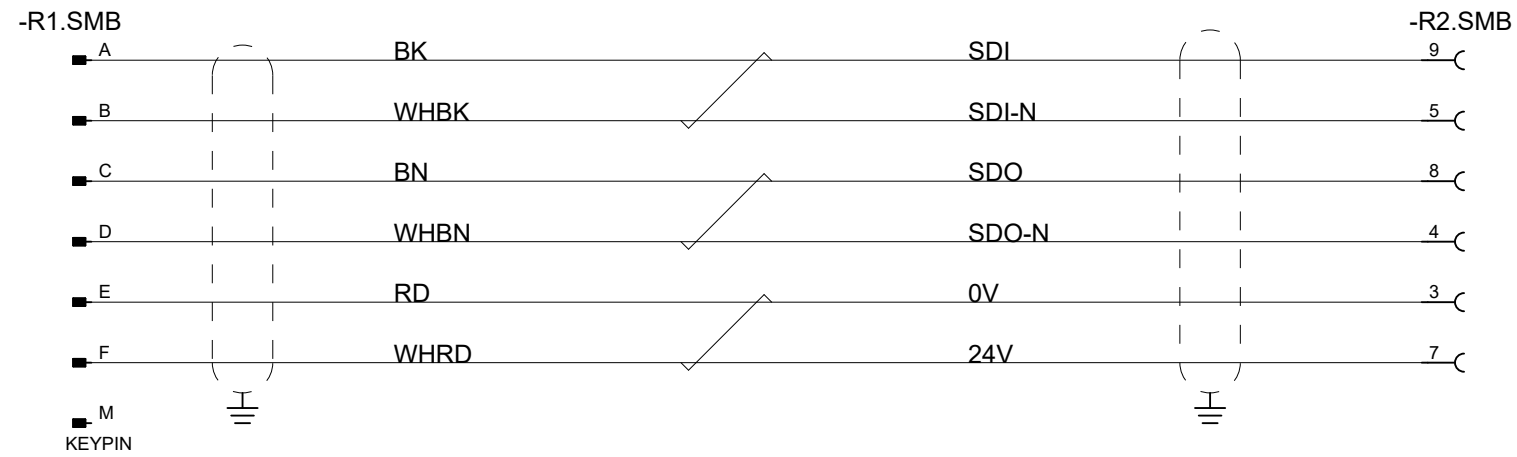
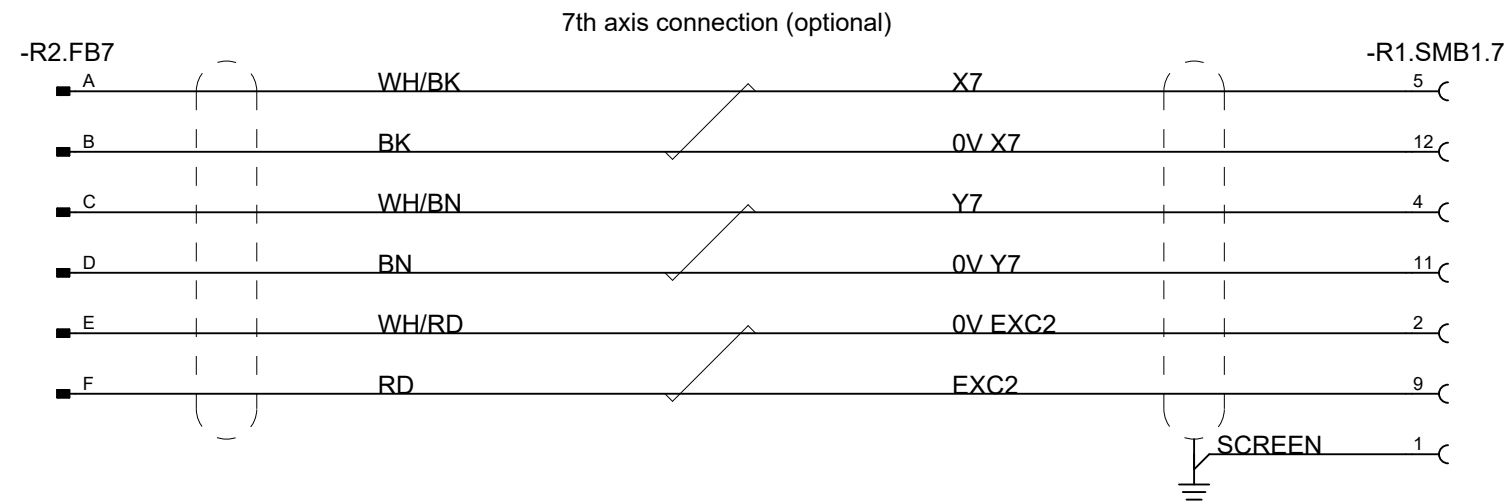

Latest revision: ECO 116452, new.



Lab/Office:
RMRO SE
RDM2

IRB 5710/5720

SMB, incl optional 7th axis connection

Status: 2021-10-29

APPROVED

Document no.

3HAC080367-001

Plant: = IRB57XX

Location: + SMB

Sublocation: +

Rev. Ind

00

Page 20

+Axis1/30

Total 13

Prepared by, date: Mattias Lindevall

Approved by, date: Mattias Lövmemark

We reserve all rights in this document and in the information contained therein. Reproduction, use or disclosure to third parties without express authority is strictly forbidden. © Copyright 2003 ABB

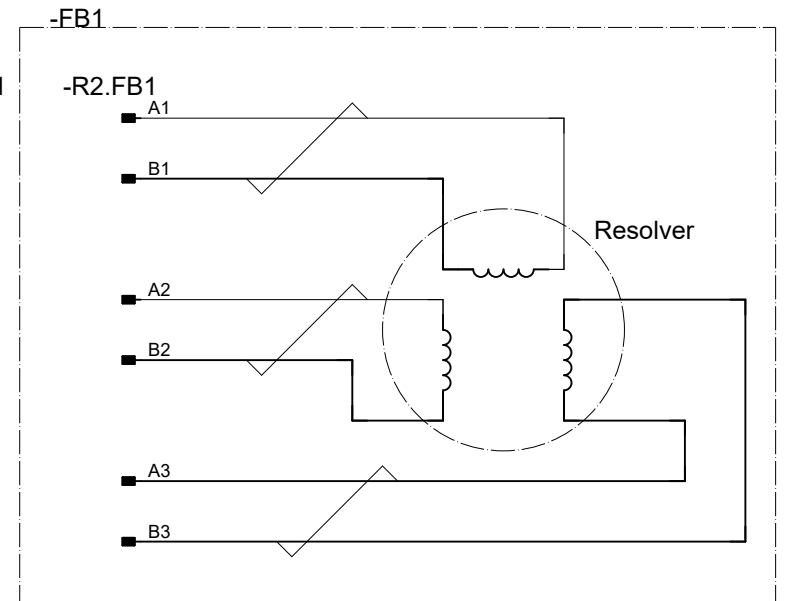
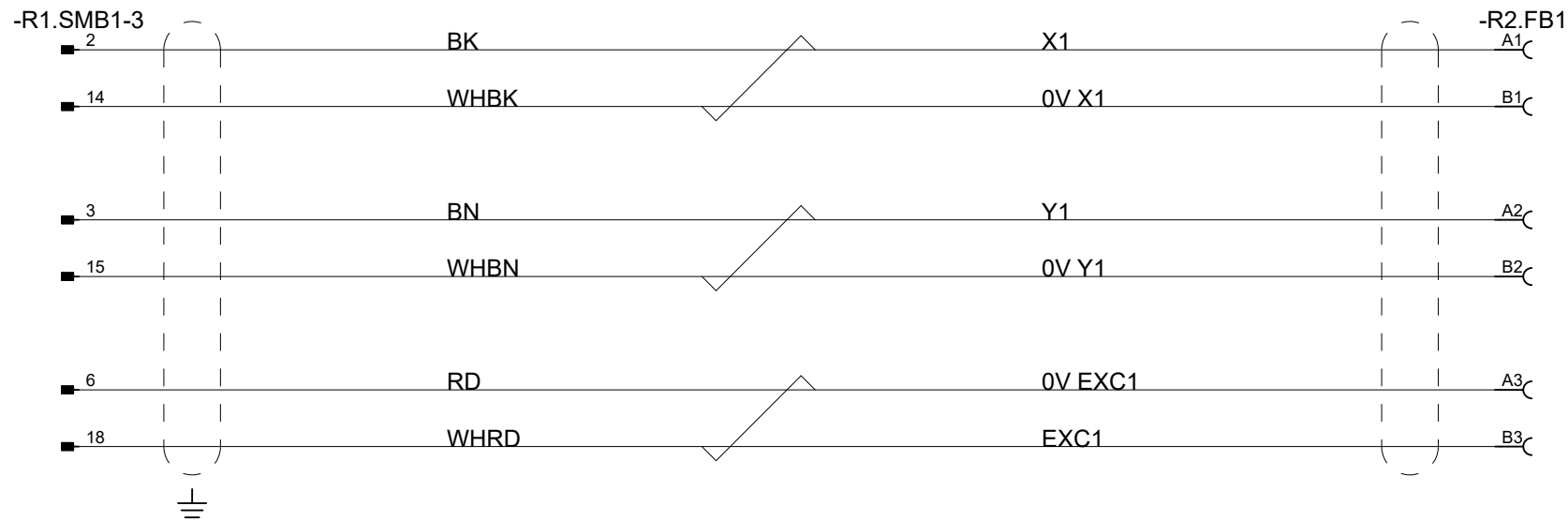
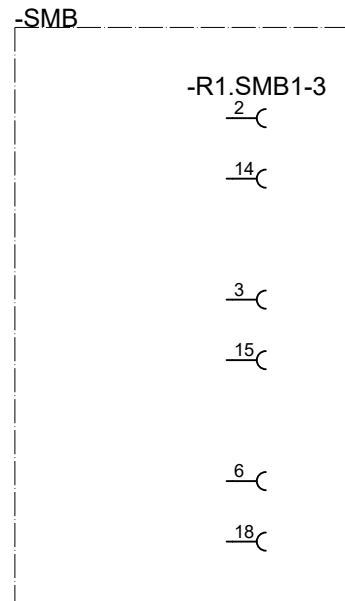
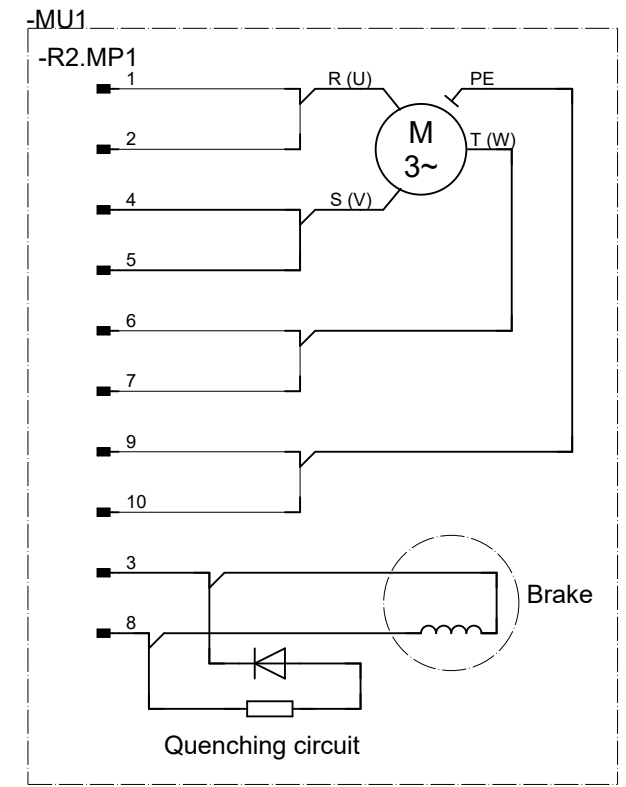
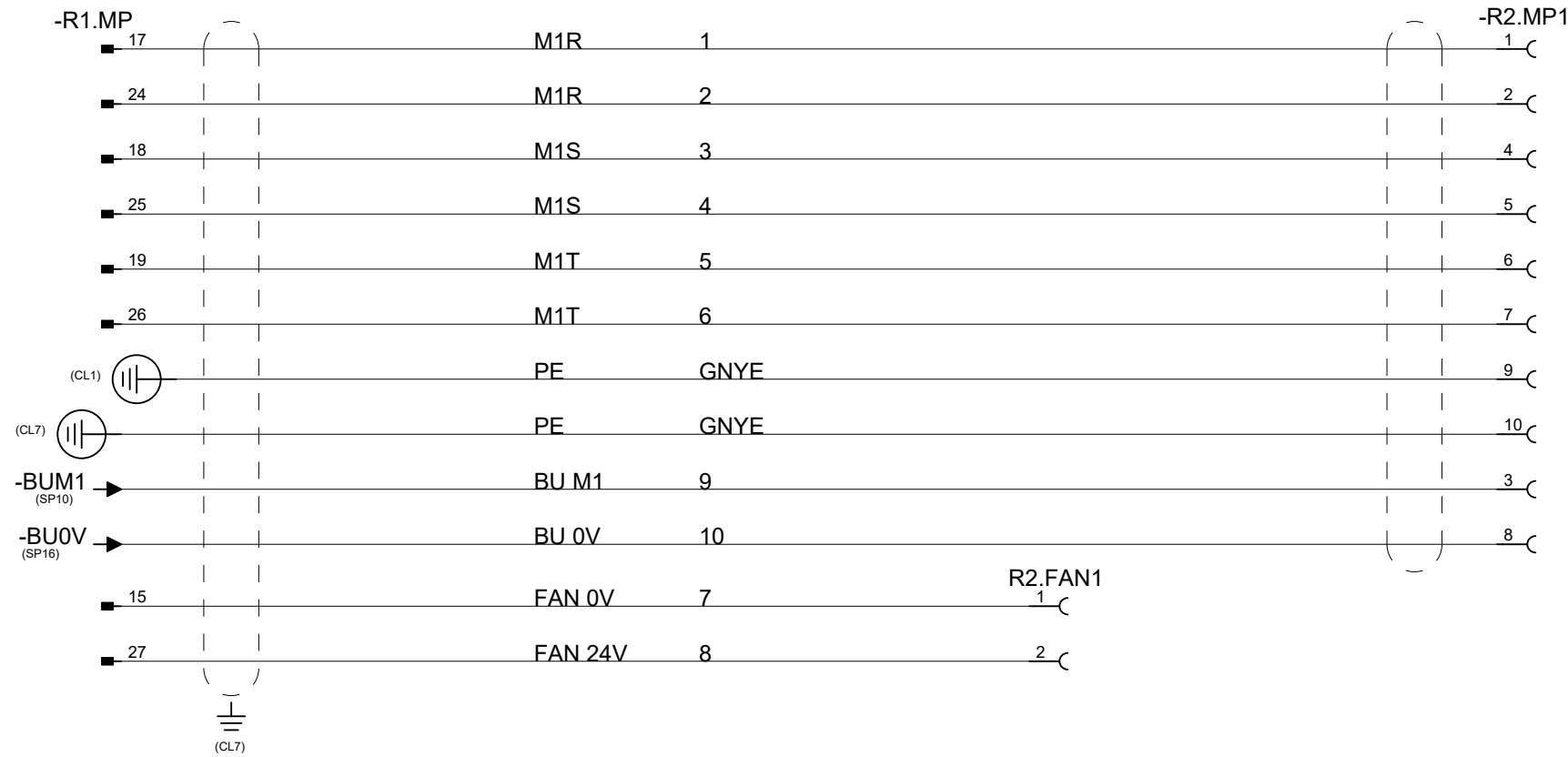

Latest revision: ECO 116452, new.



Lab/Office:
RMRO SE
RDM2

IRB 5710/5720

Axis 1

Status: 2021-10-29

APPROVED

Document no.

3HAC080367-001

Plant: = IRB57XX

Location: + Axis1

Sublocation: +

Rev. Ind

00

Page 30

+Axis2/40

Total 13

Prepared by, date: Mattias Lindevall

Approved by, date: Mattias Lövmemark

We reserve all rights in this document and in the information contained therein. Reproduction, use or disclosure to third parties without express authority is strictly forbidden. © Copyright 2003 ABB

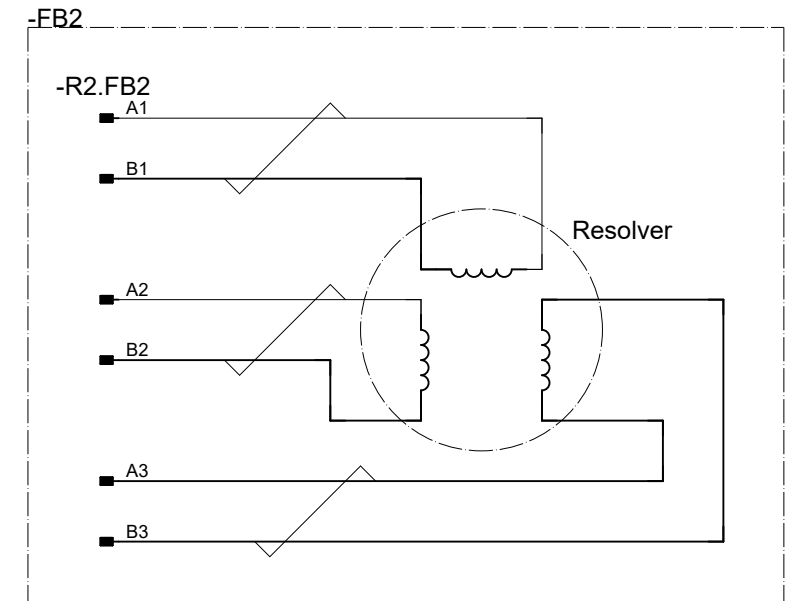
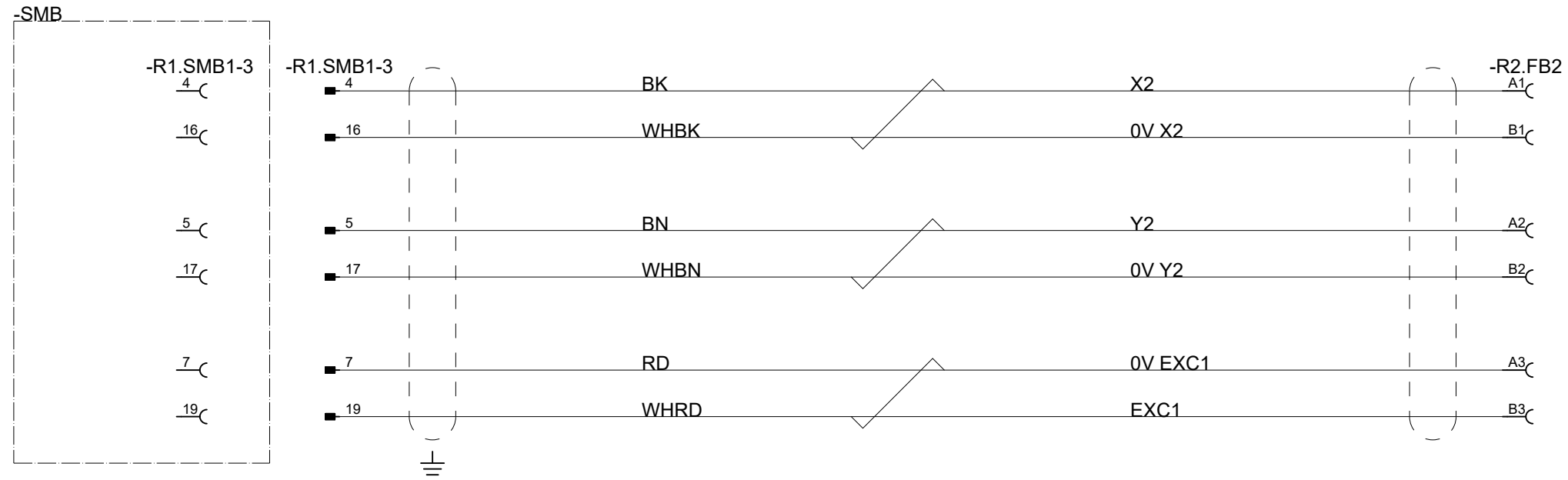
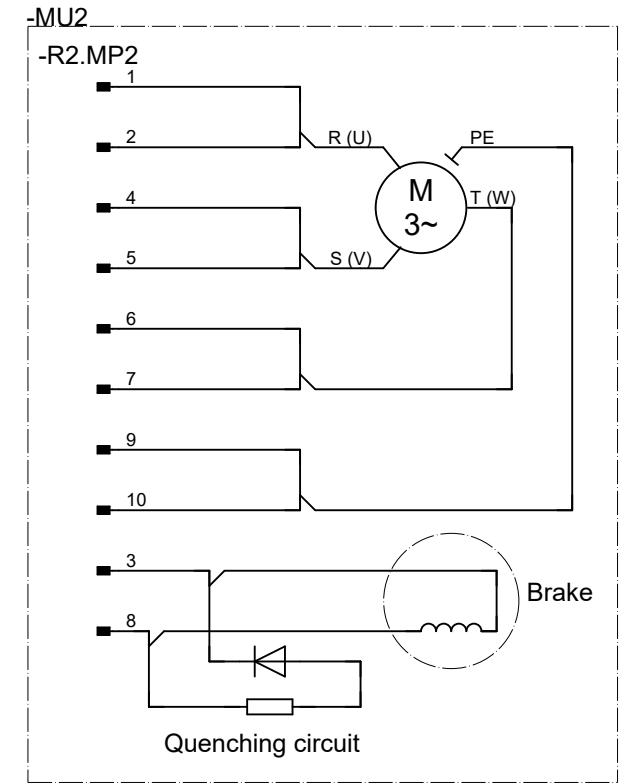
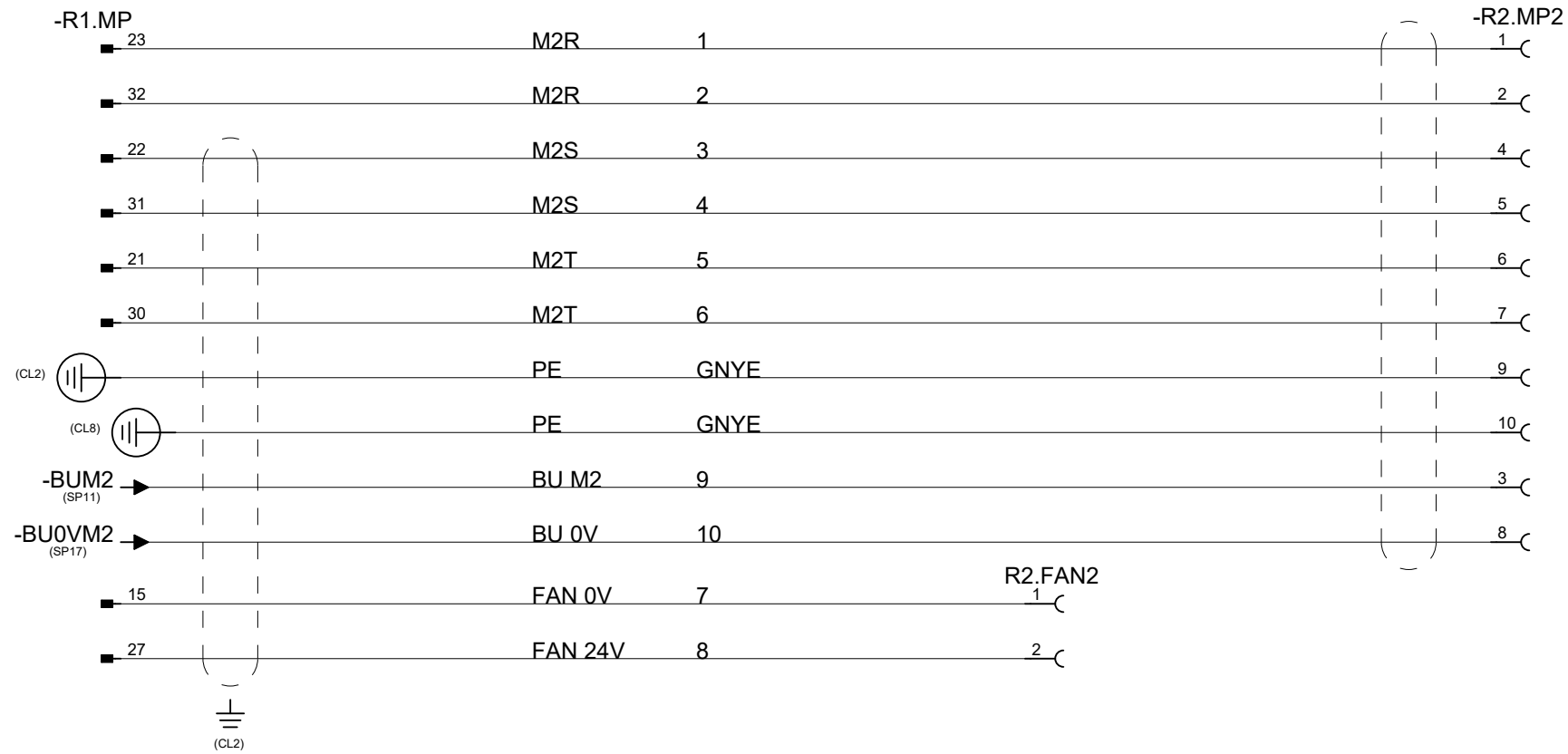

Latest revision: ECO 116452, new.



Lab/Office:
RMRO SE
RDM2

IRB 5710/5720

Axis 2

Status: 2021-10-29

APPROVED

Document no.

3HAC080367-001

Plant: = IRB57XX

Location: + Axis2

Sublocation: +

Rev. Ind

00

Page 40

+Axis3/50

Total 13

Prepared by, date: Mattias Lindevall

Approved by, date: Mattias Lövmemark

We reserve all rights in this document and in the information contained therein. Reproduction, use or disclosure to third parties without express authority is strictly forbidden. © Copyright 2003 ABB

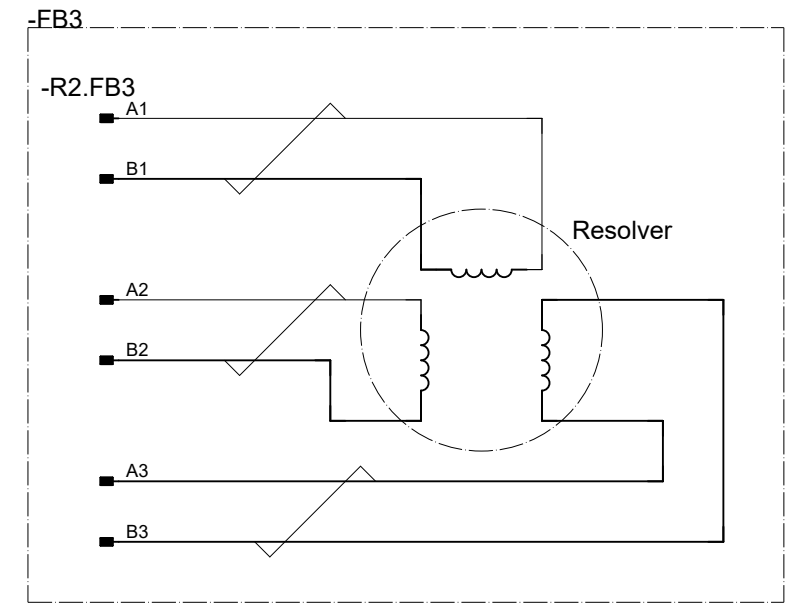
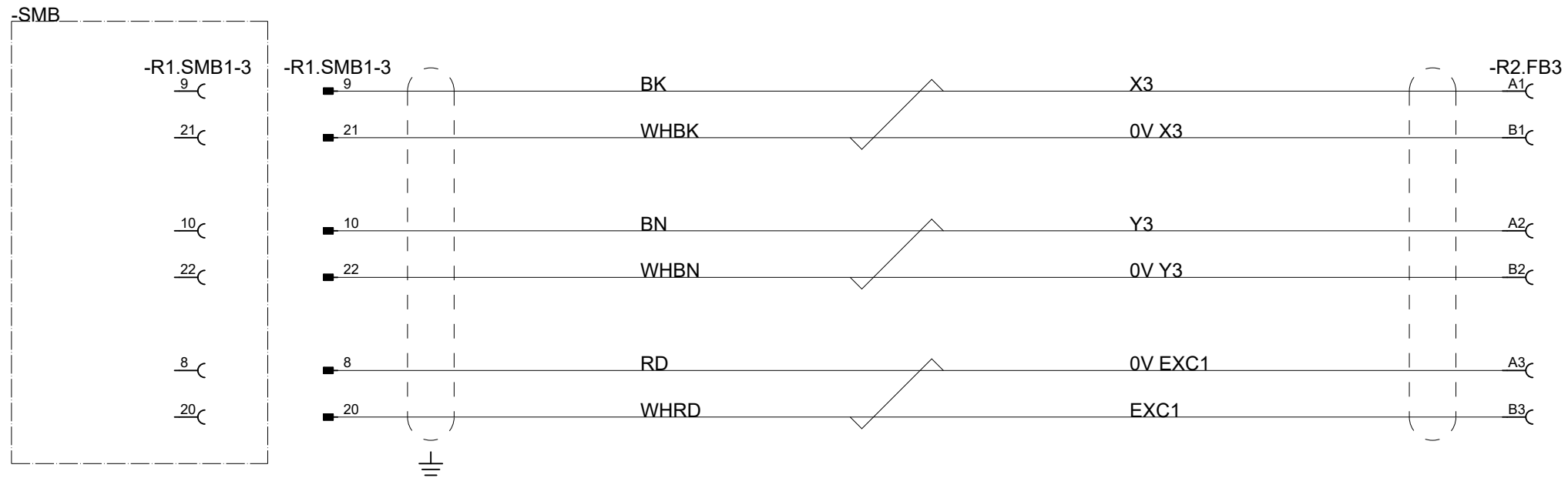
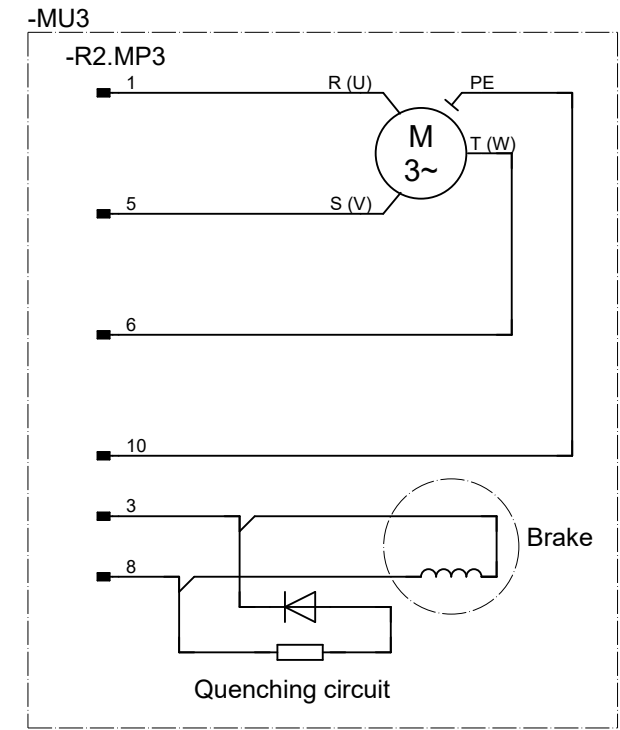
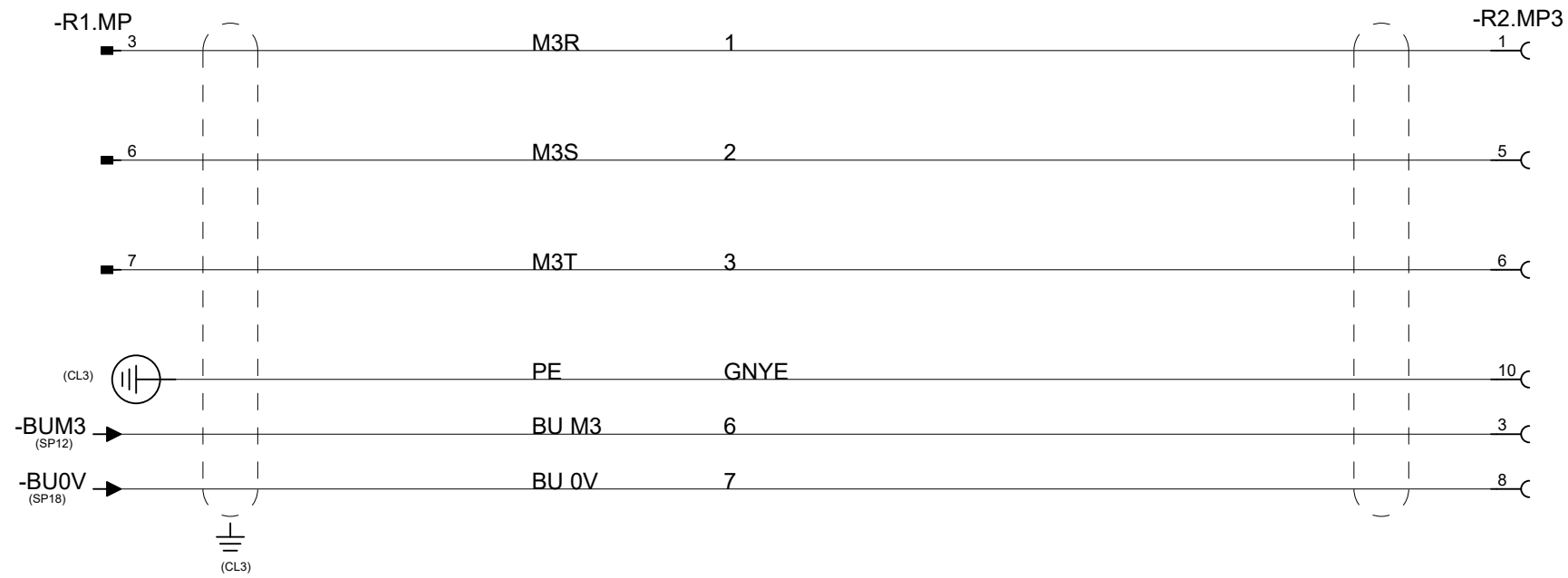

Latest revision: ECO 116452, new.

Prepared by, date: Mattias Lindevall Approved by, date: Mattias Lövmemark

ABB Lab/Office: RMRO SE RDM2

IRB 5710/5720
Axis 3, incl. optional signal lamp

Status: 2021-10-29
APPROVED
Document no. 3HAC080367-001

Plant: = IRB57XX
Location: + Axis3
Sublocation: +

Rev. Ind 00 Page 50
+Axis4/60
Total 13

We reserve all rights in this document and in the information contained therein. Reproduction, use or disclosure to third parties without express authority is strictly forbidden. © Copyright 2003 ABB

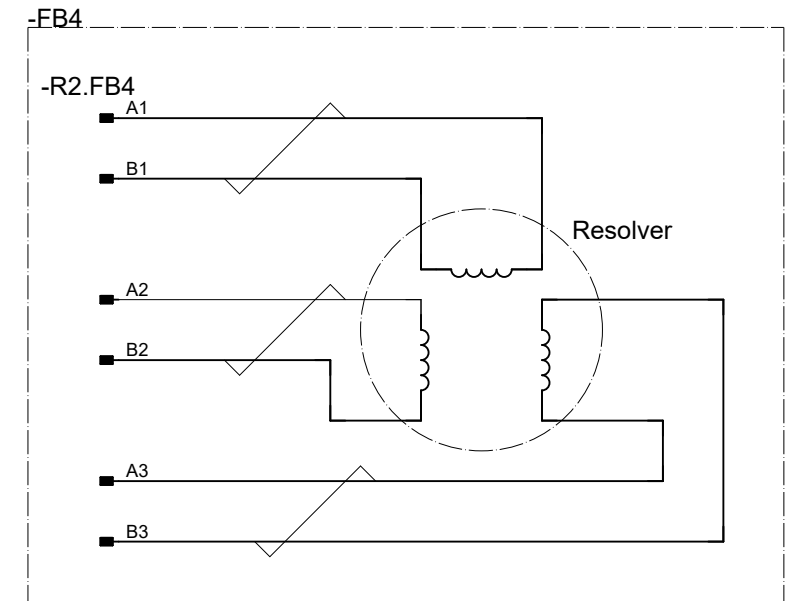
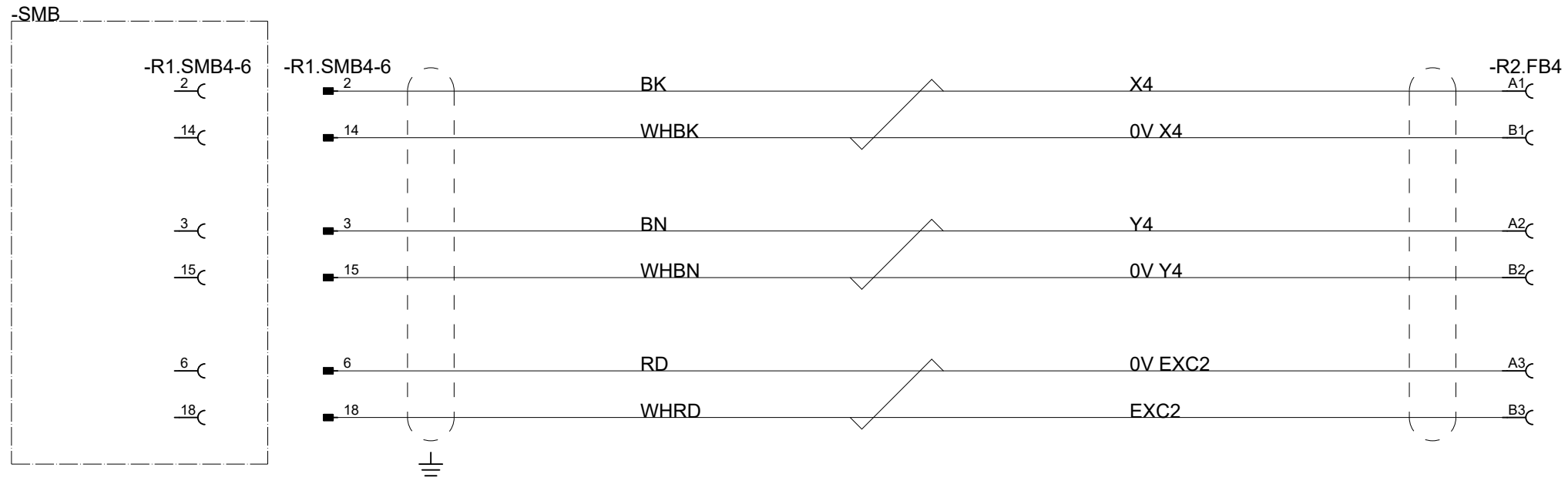
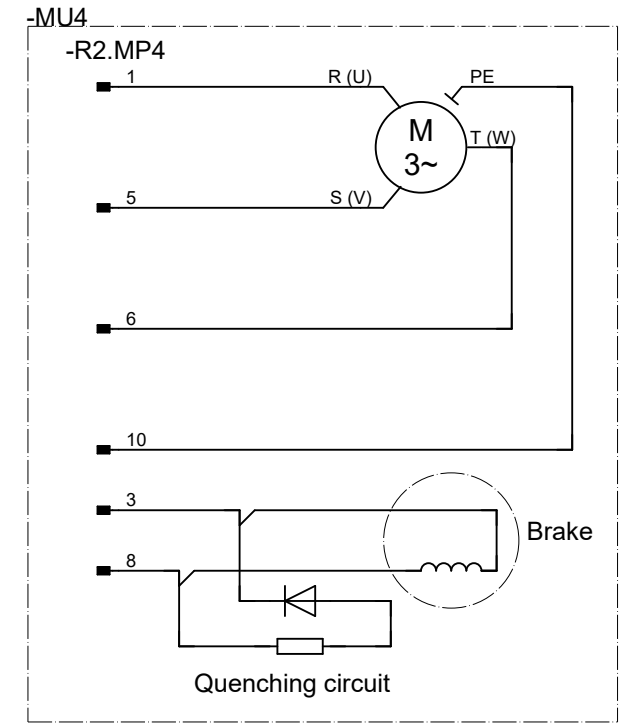
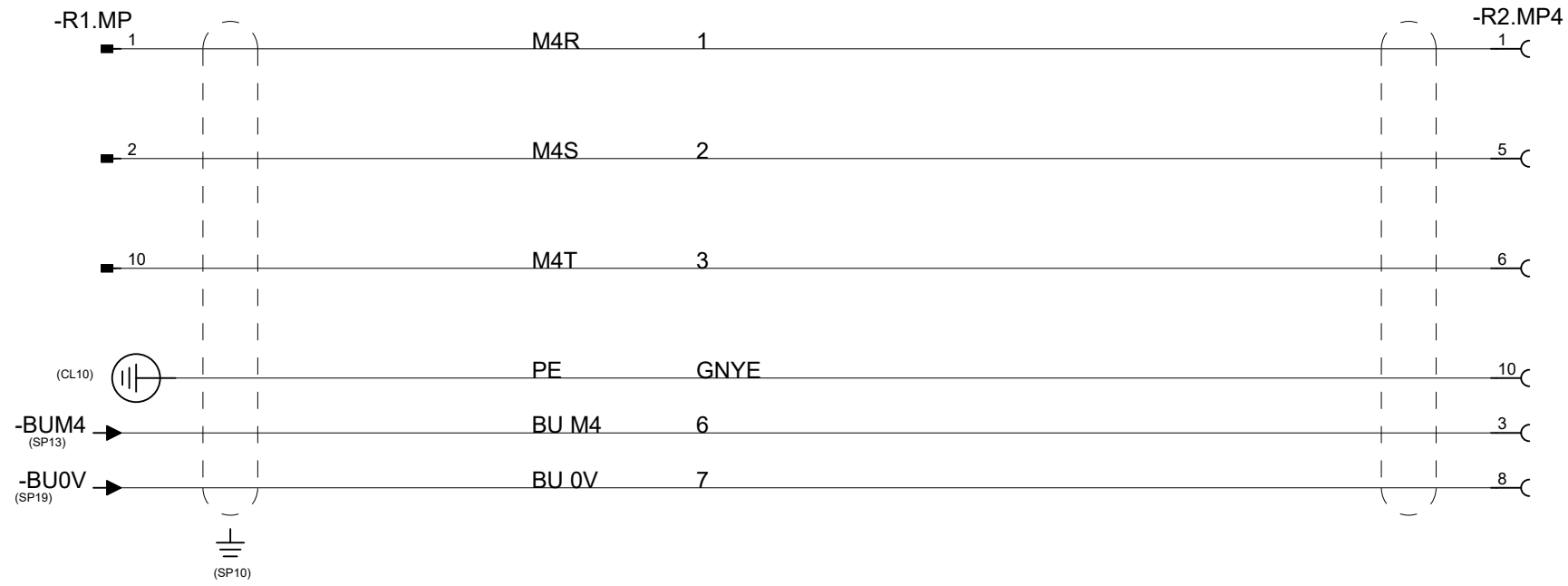

Latest revision: ECO 116452, new.



Lab/Office:
RMRO SE
RDM2

IRB 5710/5720

Axis 4

Status: 2021-10-29

APPROVED

Document no.

3HAC080367-001

Plant: = IRB57XX

Location: + Axis4

Sublocation: +

Rev. Ind

00

Page 60

+Axis 5/70

Total 13

Prepared by, date: Mattias Lindevall

Approved by, date: Mattias Lövmemark

We reserve all rights in this document and in the information contained therein. Reproduction, use or disclosure to third parties without express authority is strictly forbidden. © Copyright 2003 ABB

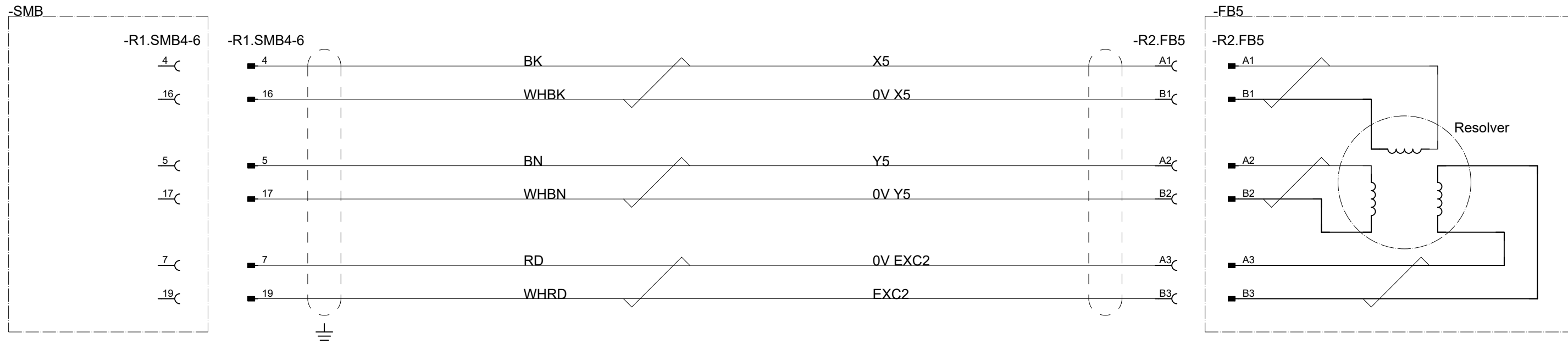

Latest revision: ECO 116452, new.



Lab/Office:
RMRO SE
RDM2

IRB 5710/5720

Axis 5

Status: 2021-10-29

APPROVED

Document no.

3HAC080367-001

Plant: = IRB57XX

Location: + Axis 5

Sublocation: +

Rev. Ind

00

Page 70

+Axis6/80

Total 13

Prepared by, date: Mattias Lindevall

Approved by, date: Mattias Lövmemark

We reserve all rights in this document and in the information contained therein. Reproduction, use or disclosure to third parties without express authority is strictly forbidden. © Copyright 2003 ABB

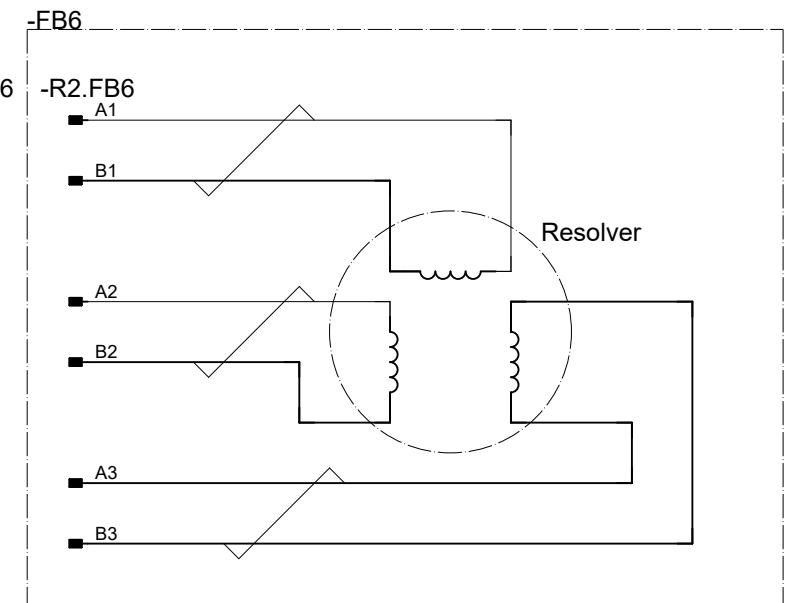
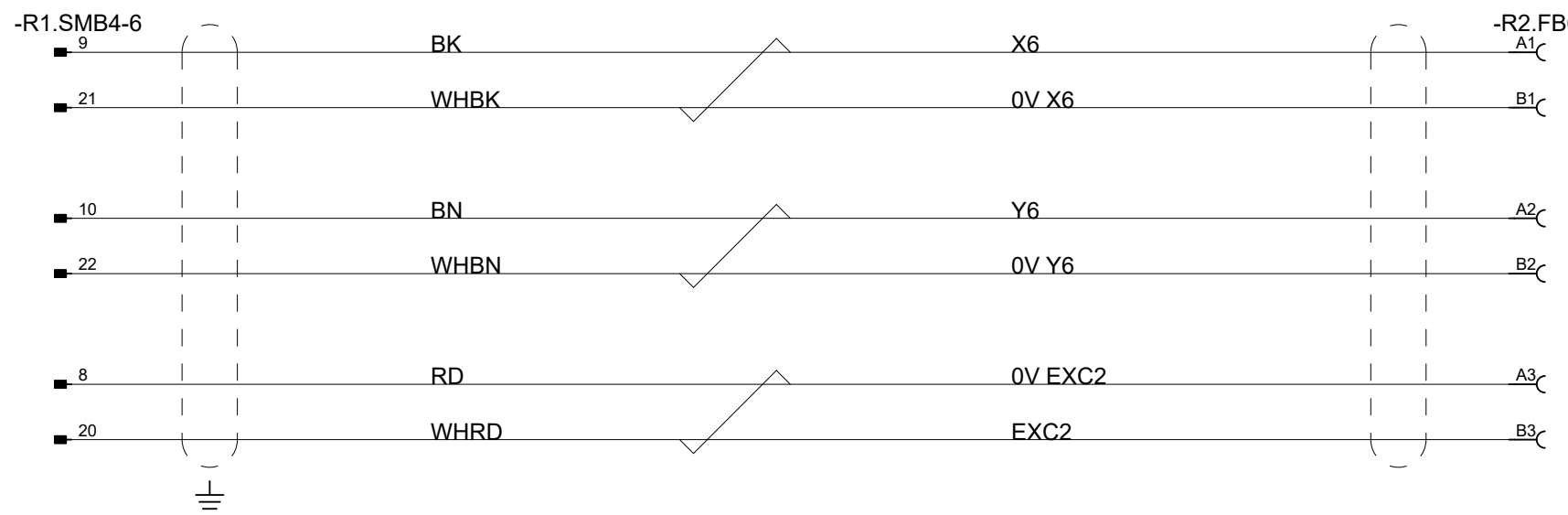
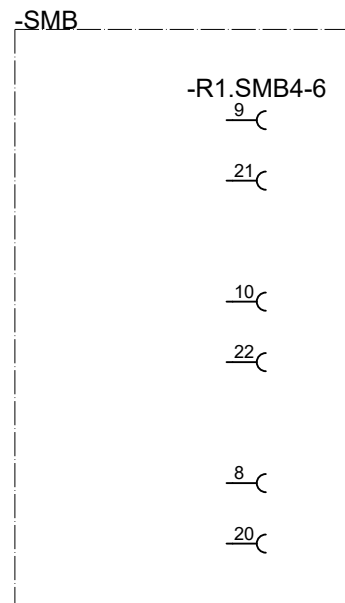
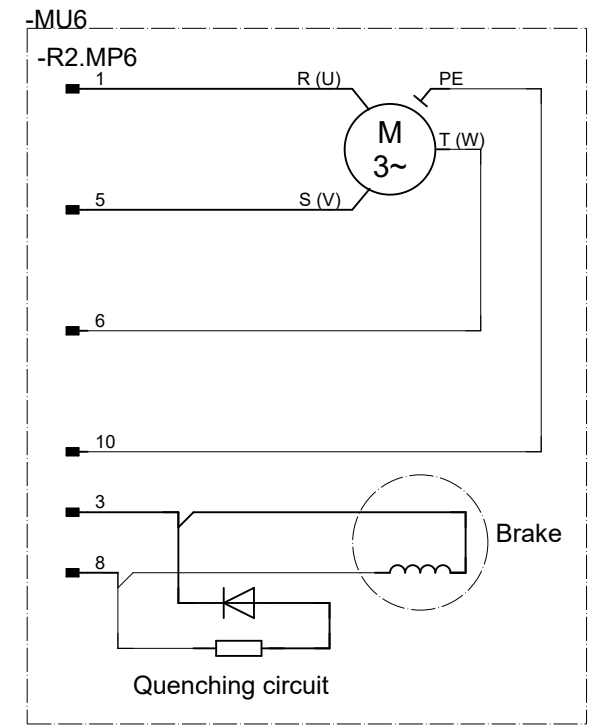
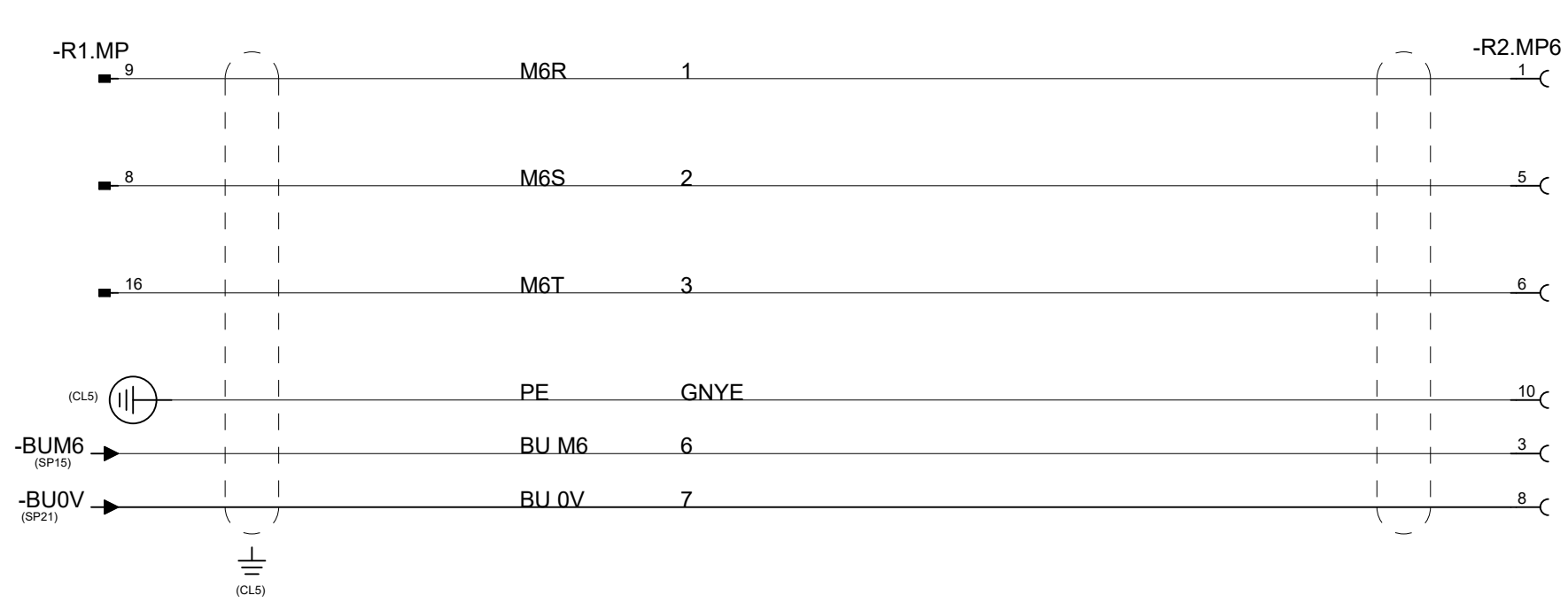

Latest revision: ECO 116452, new.

Prepared by, date: Mattias Lindevall Approved by, date: Mattias Lövmemark

ABB Lab/Office: RMRO SE RDM2

IRB 5710/5720
Axis 6

Status: 2021-10-29
APPROVED
Document no. 3HAC080367-001

Plant: = IRB57XX
Location: + Axis6
Sublocation: +

Rev. Ind 00 Page 80
Total 13